

115 HEDGER ROAD

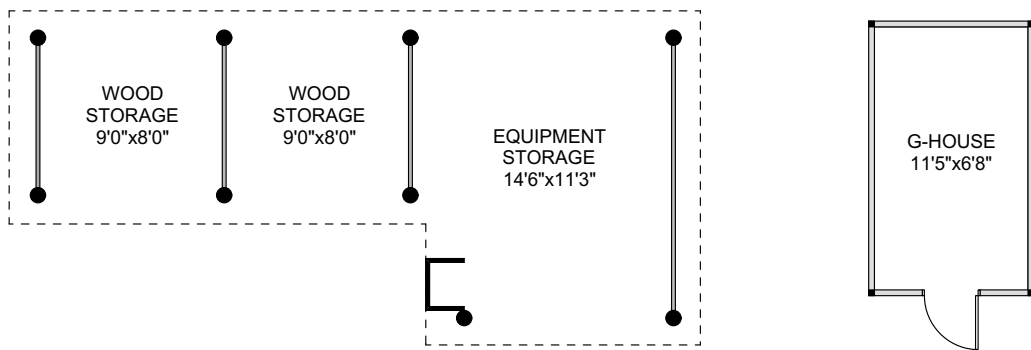

	FINISHED SQ. FT.	UNFINISHED SQ. FT.	TOTAL SQ. FT.
MAIN	1258	0	1258
UPPER	939	81	1020
TOTAL	2197	81	2278
CARPORT	0	181	181
PORCH	0	182	182
DECKS	0	211	211
WORKSHOP	0	752	752
G-HOUSE	0	85	85

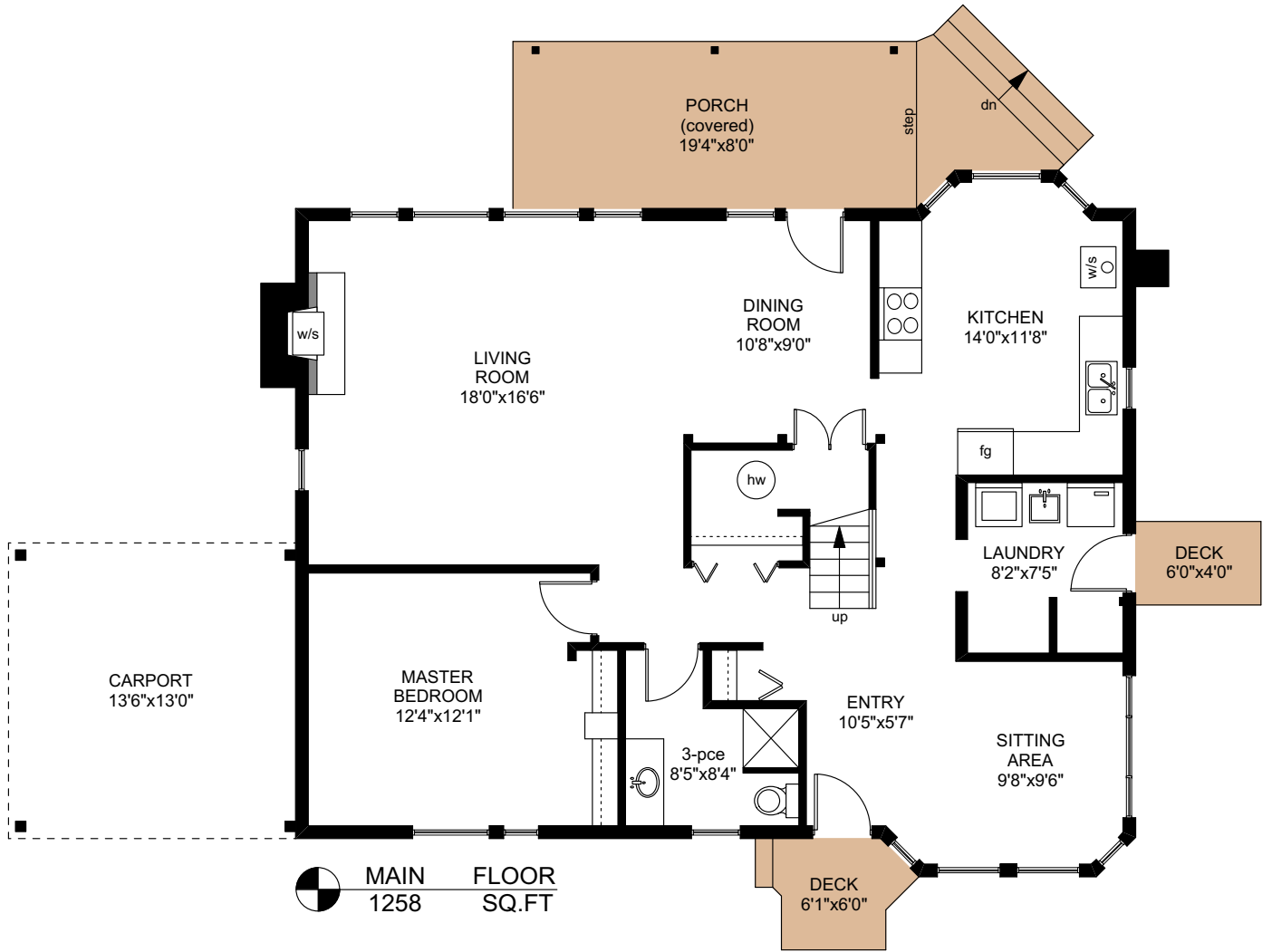
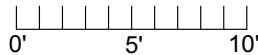
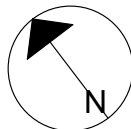

PREPARED FOR THE EXCLUSIVE USE OF
 CHRIS & DARLENE HOBBS OF
 SOTHEBY'S INTERNATIONAL REALTY CANADA
 MEASURED ON: 09/15/18
 DRAWING FILE: 0256

NOTE: This floor plan is provided by Chris & Darlene Hobbs of Sotheby's International Realty Canada as a convenient reference only, and is not to be relied upon as accurate. Prospective Buyers must satisfy themselves not only of the actual measurements, but also to the status of any finished space shown on this floor plan, specifically in relation to minimum ceiling height for habitable rooms required by the BC Building Code, allowable finished floor area in relation to current zoning, and determination if space was developed with necessary municipal permits.

115 HEDGER ROAD

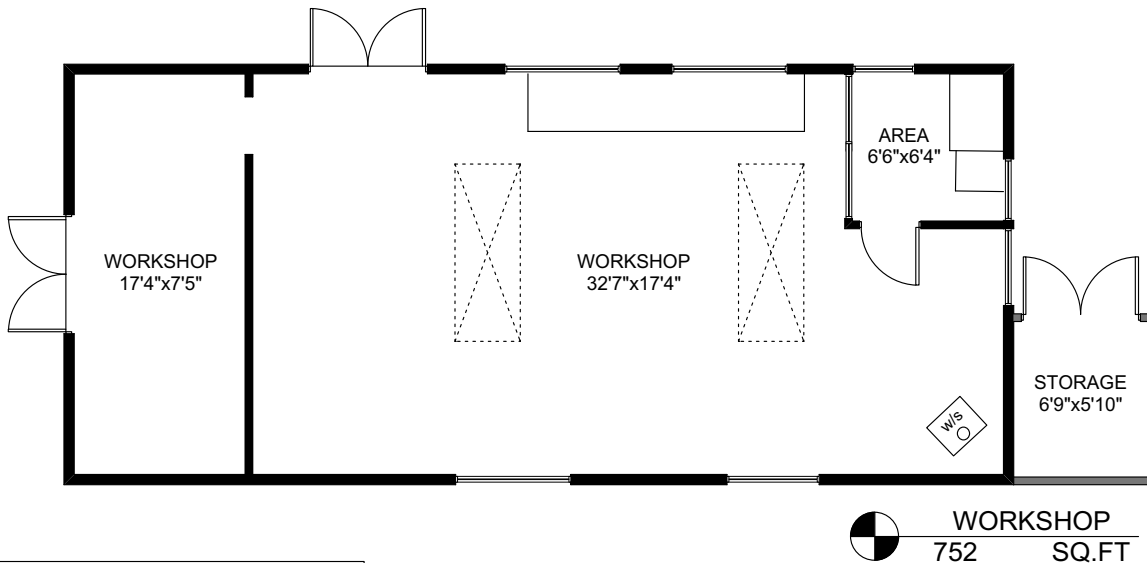
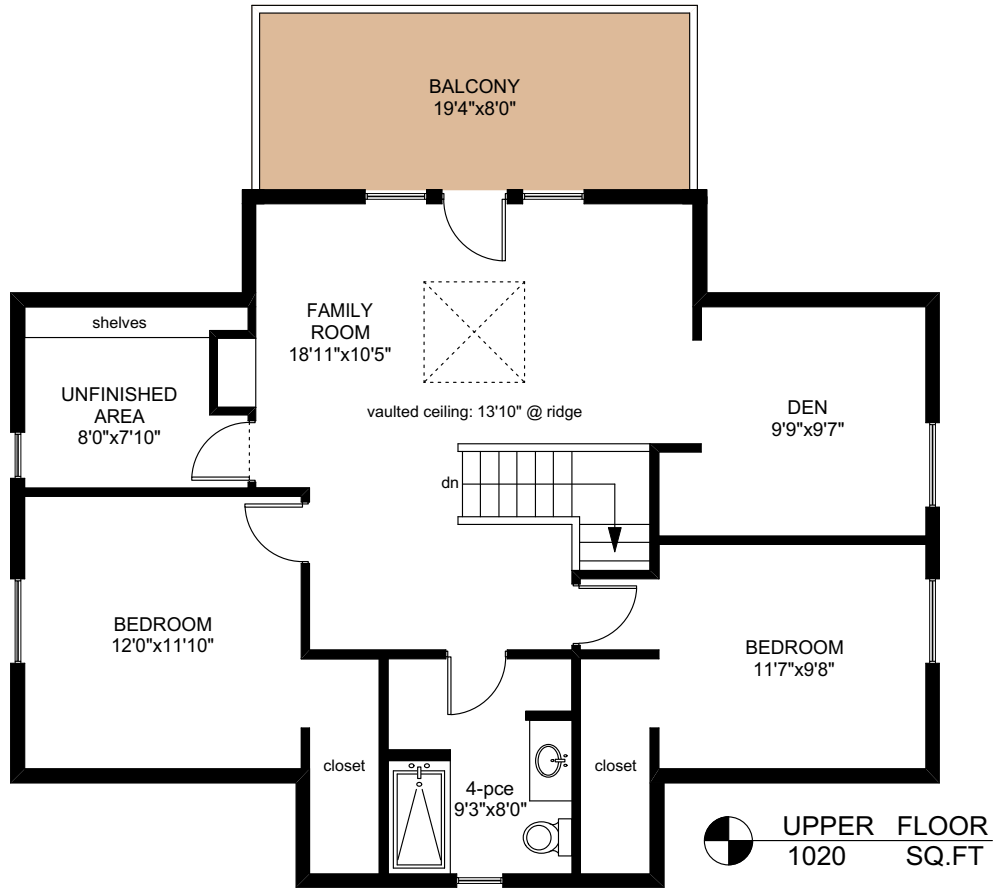

	FINISHED SQ. FT.	UNFINISHED SQ. FT.	TOTAL SQ. FT.
MAIN	1258	0	1258
UPPER	939	81	1020
TOTAL	2197	81	2278
CARPORT	0	181	181
PORCH	0	182	182
DECKS	0	211	211
WORKSHOP	0	752	752
G-HOUSE	0	85	85

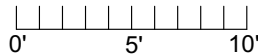
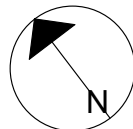

PREPARED FOR THE EXCLUSIVE USE OF
CHRIS & DARLENE HOBBS OF
SOTHEBY'S INTERNATIONAL REALTY CANADA

MEASURED ON: 09/15/18
DRAWING FILE: 0256

NOTE: This floor plan is provided by Chris & Darlene Hobbs of Sotheby's International Realty Canada as a convenient reference only, and is not to be relied upon as accurate. Prospective Buyers must satisfy themselves not only of the actual measurements, but also to the status of any finished space shown on this floor plan, specifically in relation to minimum ceiling height for habitable rooms required by the BC Building Code, allowable finished floor area in relation to current zoning, and determination if space was developed with necessary municipal permits.